



AP100 & AP200 HAZARDOUS AREA ACCESS POINT ENCLOSURE



- Designed for Class 1, Division 1, Hazardous Locations
- 802.11 b/g
- Available for Symbol and Cisco access points
- Explosion proof antennas
- ATEX certification for Explosion Proof enclosure and antennas available

The AP100 and AP200 hazardous area access point enclosures are design to accommodate the Symbol AP-300 or Cisco AIR-AP1242AG-A-K9 access points. The AP100 and AP200 are utilized to extend the 802.11b/g network into the hazardous area. The design incorporates two patented CTX-2400-TR Class 1, Div 1 antennas. The enclosure includes a mounting bracket, hardware and antenna cables to easily mount the Symbol or Cisco access points. The indicators on the Symbol access point are viewable through the glass window. Other access points may be used, contact the factory for more information.

Ratings:

Class 1, Division 1, Groups C & D
-40°C to +85°C

Specifications:

Size: 13.38w x 15.51h x 6.25d (dimensions in inches)
Antenna gain: 2.0dBi
Frequency: 2.4 GHz

Ordering information:

<u>Part Number</u>	<u>Designed for</u>
AP100	Symbol AP-300 access port
AP200	Cisco AIR-AP1242AG-A-K9 (2.4 GHz side) access point
AP200-1	Cisco AIR-AP1242AG-A-K9 (2.4 GHz side) access point no window

Note: Symbol and Cisco access points are sold separately.

DWG. NO. SD-D-0271B	
REVISIONS	
B	MOVED ETHERNET PORT 3/19/10 RML

TOP VIEW

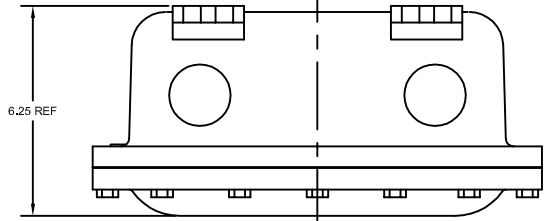

FRONT VIEW

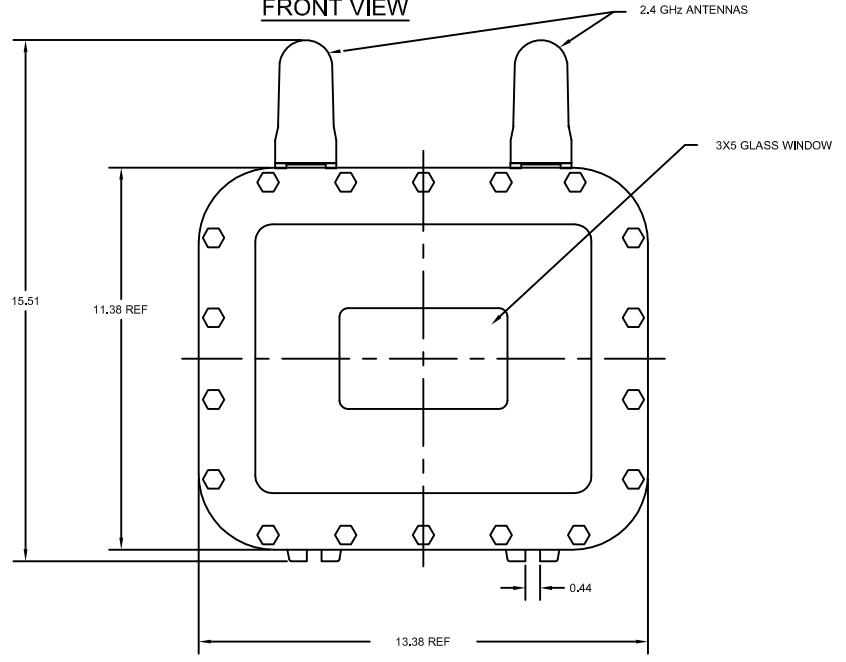

RIGHT SIDE VIEW

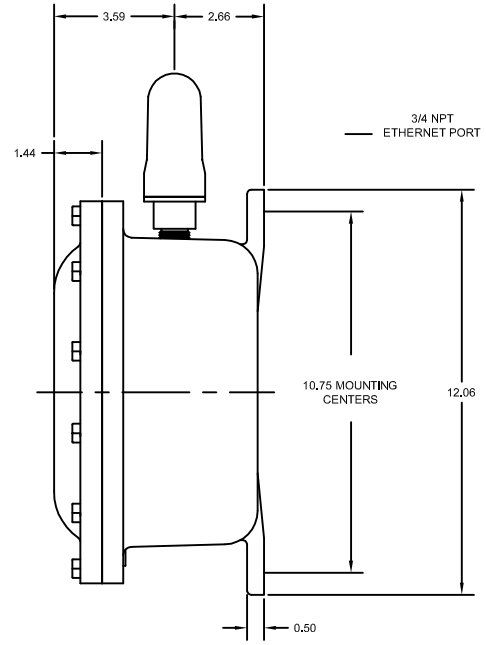

BOTTOM VIEW

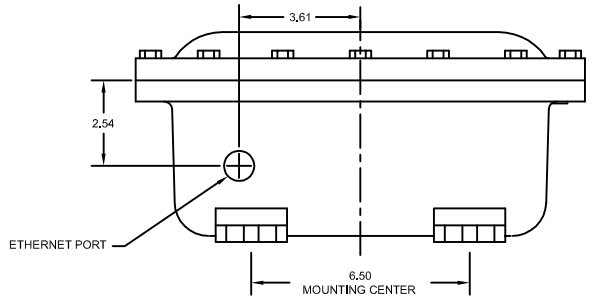

DWG. SD-D-0271B

- NOTES:
1. ENCLOSURE: CLS 1, DIV 1 EXPLOSION PROOF.
 2. ACCESS POINT: SYMBOL WSAP-5100-050-WVV.
 3. ANTENNAS: CLS 1, DIV 1, GROUPS C & D EXPLOSION PROOF CTX-2400-TR, QTY 2.
 4. ORDERING INFORMATION: AP100.
 5. ALL DIMENSIONS ARE IN INCHES.

QUOTE OR ORDER NUMBER			Analylnk Wireless, LLC 790 CROSS POINTE ROAD COLUMBUS, OHIO 43230		
DRAWN BY			DATE		
CHECKED BY			DATE		
APPROVED BY			DATE		
TITLE FOR ACCESS POINT AP100 CLS1 DIV1			NEXT ASSY		
DWG NO. SD-D-0271B					

FILE NAME EU000125.DWG	CHECKED DATE	DATE 12/27/06
---------------------------	-----------------	------------------

DWG. NO.	SD-D-0272B
REVISIONS	
B	MOVED ETHERNET PORT 3/19/10 RML

DWG. SD-D-0272B

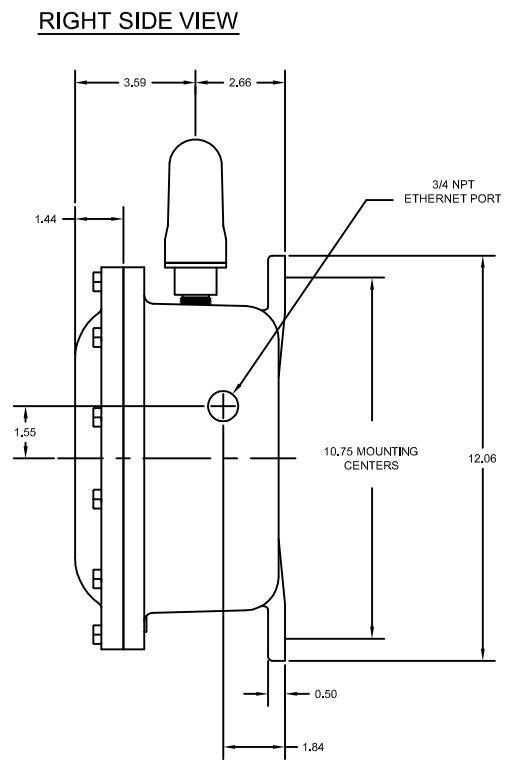
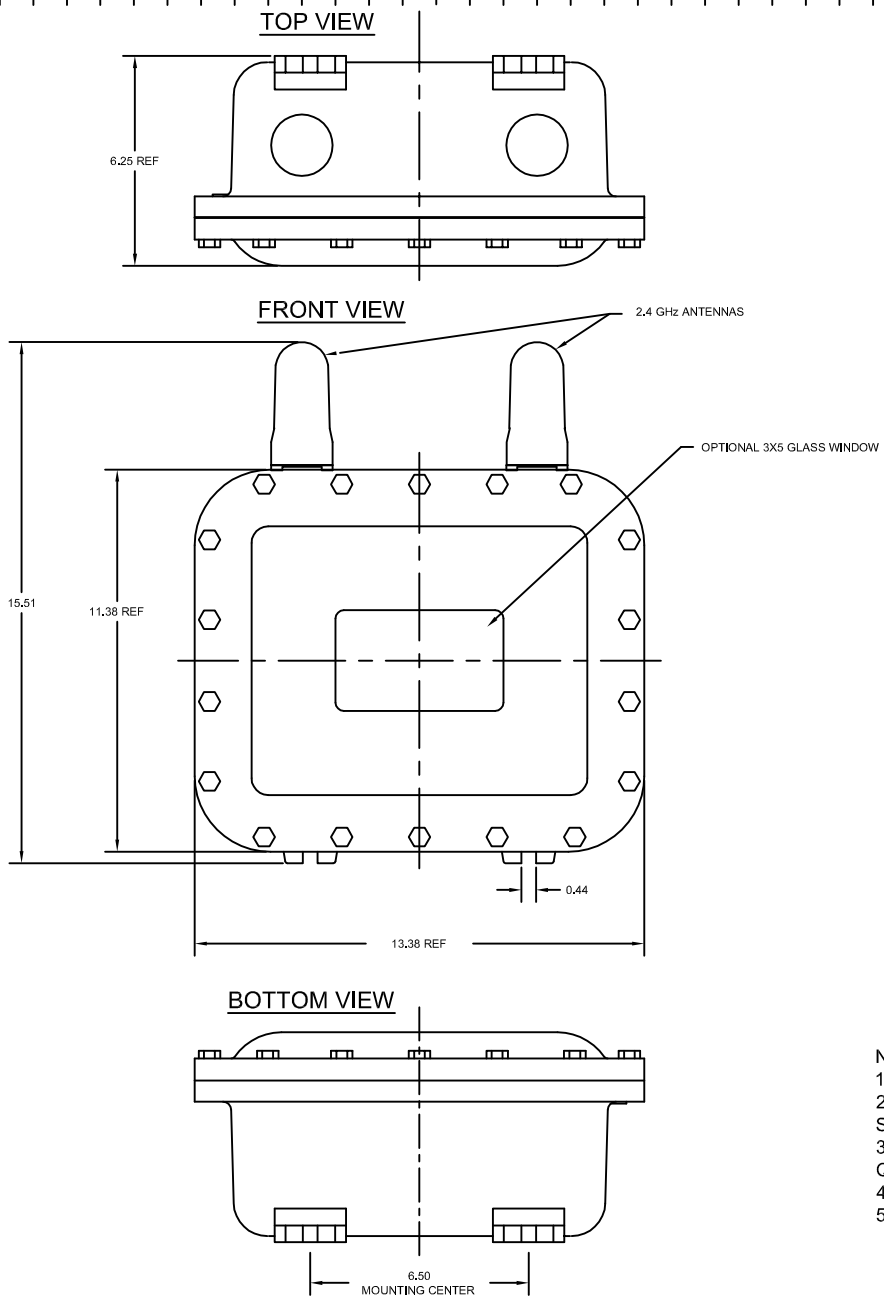

- NOTES:
- ENCLOSURE: CLS 1, DIV 1 EXPLOSION PROOF XCE 081004.
 - ACCESS POINT: CISCO AIR-AP1242AG-A-K9, USING 2.4GHz SIDE ONLY.
 - ANTENNAS: CLS 1, DIV 1 EXPLOSION PROOF CTX-2400-TR, QTY 2.
 - ALL DIMENSIONS ARE IN INCHES.
 - ORDERING INFORMATION:
ENCLOSURE WITH WINDOW: AP200
WITHOUT WINDOW: AP200-1

QUOTE OR ORDER NUMBER		Anlynk Wireless, LLC 790 CROSS POINTE ROAD COLUMBUS, OHIO 43230	
DRAWN BY		DATE	
CHECKED BY		DATE	
APPROVED BY		DATE	
FILE NAME EUD00126.DWG		NEXT ASSY	
DWG NO. SD-D-0272B		TITLE FOR ACCESS POINT AP200 CLS1 DIV1	